



XM112 – Pulsed Coherent Radar (PCR)
Module
Datasheet v1.0

如有问题，请通过以下方式联系我们！

beyd佰誉达

深圳市佰誉达科技有限公司

0755-23282845/23592633

深圳市龙岗区龙城街道腾飞路9号创投大厦3006

www.beyd.com.cn

Acconeer中国区总代理



Abstract

The XM112 module is tailored for customer evaluation and for OEMs who wish to have the shortest time-to-market.

The XM112 can be used as a controlled module, application running on external host where XM112 is controlled by register based protocol. The XM112 can also be used as a stand-alone module where customer can embed their application on top of RSS (Radar System Software), using the RSS API (Application Programming Interface).



XM112 – Top view

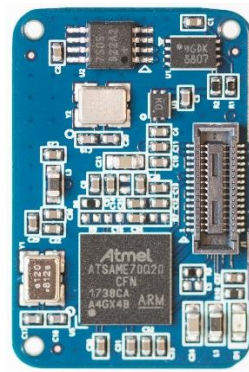

XM112 – Bottom view



1 Table of Contents

2 Revision History	4
3 Functional description	5
2.1 Overview	5
2.2 Product features	5
2.3 Block diagram	6
2.4 Module board connector and pin description	7
2.5 Software options	9
4 Interfaces	10
3.1 Module supply input (+1V8)	10
3.2 System functions	10
3.3 Serial interfaces	10
3.4 GPIO	10
3.5 Debug interfaces	10
3.5.1 Trace-Serial Wire Viewer	10
5 Electrical specifications	11
5.1 Absolute maximum ratings	11
5.2 Recommended operating conditions	11
5.3 Electrical specification	11
5.4 Power consumption summary	12
5.5 RF specification	12
6 Reference design description	13
6.1 Schematics & BOM	13
6.2 Component placement drawing	18
7 Mechanical specifications	19
8 Reference documents	21
Disclaimer	22



2 Revision History

Revision	Comment
v1.0 prel.	Preliminary version
v1.0	Tolerances added in module outline, chapter 7.0. Document put in sharp revision.

This document applies to the following product:

Product name	Part number
XM112	XM112-001 (module)



3 Functional description

3.1 Overview

The XM112 is a reference module with optimized formfactor (24x16 mm) that can be used for commercial use and for evaluation and development purpose to support customer in their own design.

The XM112 comes with Atmel ATSAME70Q20A microcontroller (MCU) and A111 Pulsed Coherent Radar (PCR) sensor, see ref [1].

The Atmel ATSAME70Q20A is based on an ARM[®] Cortex[®]-M7, 32-bit, running at up to 300 MHz, 384 Kbytes SRAM and 1 Mb Flash, see ref [2].

The XM112 is delivered with Acconeer RSS software including SDK (Software Development Kit) for stand-alone usage where customer can embed their own application on top of Acconeer RSS software. Acconeer RSS software provides API to set A111 sensor configuration and to retrieve supported radar services and detector data.

XM112 offers support as well to act as controlled by external host through register command protocol on UART, SPI and I2C.

3.2 Product features

The XM112 is a reference module based on Acconeer A111 pulsed coherent radar (PCR) and the Atmel ATSAME70Q20A microprocessor.

XM112 features:

- The A111 60 GHz Pulsed Coherent radar (PCR) with integrated baseband, RF front-end and Antenna in Package (AiP).
- The Atmel ATSAME70Q20A microprocessor base on an ARM[®] Cortex[®]-M7, 32-bit, running at up to 300 MHz, 384 Kbytes SRAM and 1 Mb Flash.
- Formfactor 24 x 16 mm
- Single supply operating voltage 1.8V
- Clock reference 24 MHz XTAL
- Operating temperature -40° to 85°C
- External interfaces SPI, UART, I2C
- SWD for SW flash and debug
- External interrupt support

The XM112 can be used for accurate distance ranging, movements and material detection:

- High precision distance measurements with high update frequency
- Measures absolute range up to 2m with an absolute accuracy in mm.
 - *Note: 2m ranging is guaranteed for an object size, shape and dielectric properties corresponding to a spherical corner reflector of 5 cm radius.*
- Measures relative accuracy in μm
- Possible to recognize movement for several objects
- Support continuous and single sweep measurement mode

Easy integration:

- Can be integrated behind plastic or glass without any need for a physical aperture
- 1.8V single power supply, enable with Power on Reset (PoR)



3.3 Block diagram

XM112 block diagram:

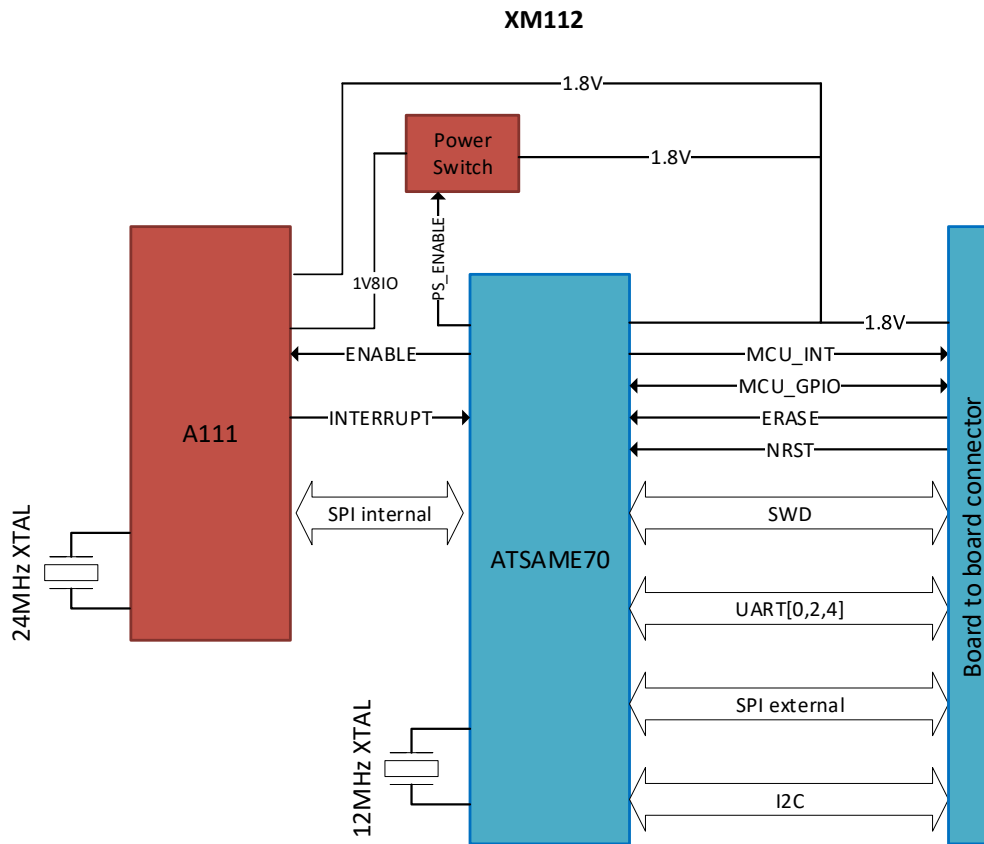

Figure 2.1 XM112 block diagram

The XM112 block diagram shows the A111 60 GHz PCR radar connected to an ATSAME70Q20A microcontroller. The module provides a pin connector where the MCU external I/F are accessible including 1.8V single voltage supply.



3.4 Module board connector and pin description

XM112 Board to board connector

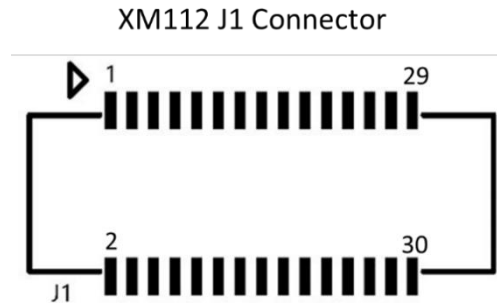

Table 2.1 shows the pinout of the XM112 connector J1.

Pin Number	Signal	Description	ATSAME7* pin
1	SPI_CLK	SPI external	PD22
2	GND	Ground	-
3	GND	Ground	-
4	+1V8	1.8V external single power supply	-
5	SPI_MOSI	SPI external	PD21
6	+1V8	1.8V external single power supply	-
7	GND	Ground	-
8	GND	Ground	-
9	SPI_MISO	SPI external	PD20
10	MCU_GPIO	General Purpose IO	PA30
11	GND	Ground	-
12	UART4_TXRX ¹	UART4 interface	PD18
13	SPI_SS	SPI external	PB2
14	UART4_RXTX ¹	UART4 interface	PD19
15	GND	Ground	-
16	ERASE	Reinitialize the MCU Flash content	PB12
17	UART0_TXRX ¹	UART0 interface	PA9
18	NRST	Reboot from Flash, HW reset	NRST
19	UART0_RXTX ¹	UART0 interface	PA10
20	SWDIO	SWD interface for flashing and debugging	PB6
21	GND	Ground	-
22	TRACESWO	SWD interface for flashing and debugging	PB5
23	UART2_TXRX ¹	UART2 interface	PD25



24	GND	Ground	-
25	UART2_RXTX ¹	UART2 interface	PD26
26	SWDCLK	SWD interface for flashing and debugging	PB7
27	I2C_SDA	I2C interface	PA3
28	GND	Ground	-
29	I2C_SCL	I2C interface	PA4
30	MCU_INT	allocated for INTERRUPT (optional)	PC2

Table 2.1: The pinout of the XM112 connector J1

¹ The first two letters in the part of the signal name that is following the “_” character indicate the direction of the UART on the external host. The last two letters of the signal name that is following the “_” character indicate the direction of the UART on the XM112 MCU.



3.5 Software options

The XM112 module can be used in two regimes:

- **Stand-alone module:** The module has got no dependency on external controllers. The application is customized to a specific use case by the customer and runs on the embedded MCU. The customers application is accessing the RSS API via a software interface.
- **Controlled module:** The module is connected to an external controller where the customer runs their application software. The customers are accessing the RSS API via a hardware interface through the module server, that provides register mapped protocol. The module output is either detector output data or service radar data through the XM112 external interfaces such as SPI, UART and I2C.

Using the XM112 as Stand-alone module Acconeer offers SDK that provides RSS, hardware abstraction layer, device drivers and build system provided as source code and as well example applications. Based on SDK it is possible for the customer to develop their own application. Both RSS and applications that runs on the embedded MCU.

Using the XM112 as Controlled module Acconeer provides SW image including RSS and module server application that provides hardware interface accessing the RSS API through a register mapped protocol, see ref [4].

For further software information, see XM112 Module Evaluation Kit User guide, ref [3].



4 Interfaces

4.1 Module supply input (+1V8)

The XM112 support 1.8V external single power supply. Note that supply voltage conditions (E.g. slew rate) need to be taken into consideration according to ATSAME70 data sheet, ref [2].

4.2 System functions

The XM112 module supports Running and Sleep system power states, see XM112 Module server User guide, Ref [4] for further information.

Module RESET is supported by activating NRST pin (active low).

Module ERASE is used to reinitialize the MCU Flash content and some of its NVM (Non-Volatile Memory) bits to an erased state. See ATSAME70 data sheet, ref [2] for further information.

4.3 Serial interfaces

The XM112 module support UART, SPI and I2C external serial interfaces.

Three UART (UART0, UART2, UART4) can be used for serial communication and UART0 can be used for software flashing, see ATSAME70 data sheet, ref [2] for further information.

4.4 GPIO

The XM112 module support two General Purpose IOs (GPIOs). MCU_INT and MCU_GPIO.

MCU_GPIO is used as a General Purpose IO pin. MCU_INT is allocated for INTERRUPT (optional). Note that MCU_INT is using GPIO pin C2 on the ATSAME70 MCU.

4.5 Debug interfaces

The XM112 module provide an SWD interface for flashing and debugging. The SWD interface consists of two pins: SWDCLK and SWDIO.

4.5.1 Trace – Serial Wire Viewer

A serial trace option will also be available as an additional pin: SWO. The Serial Wire Output is used to:

- Support printf style debugging
 - Note: Log data is retrieved on UART2_RXTX (pin 25)
- Trace OS and application events
- Emit diagnostic system information

A debugger that supports Serial Wire Viewer (SWV) is required. The trace function can be used only when developing a custom application.



5 Electrical specifications

5.1 Absolute maximum ratings

The below table shows the XM112 absolute maximum ratings over operating temperature range, on package, unless otherwise noted:

Parameter	Description	Min.	Max.	Unit
+1V8	1.8 V power supply	0	2.0	V
I/O	Voltage on I/O Pins with Respect to Ground	-0.3	4.0	V
T _{OP}	Operating temperature range	-40	85	°C
T _{STG}	High temperature storage		125	°C

Table 4.1. Absolute maximum ratings

Stresses beyond those listed in table 5.1 may cause permanent damage to the device. These are stress ratings only and functional operation of the device at these conditions or at any other conditions beyond those indicated under Recommended Operating Conditions is not implied. Exposure to absolute-maximum-rated conditions for extended periods of time may affect device reliability.

5.2 Recommended operating conditions

The below table shows the XM112 recommended operating conditions, on package:

Parameter	Min.	Typ.	Max.	Unit
Operating power supply voltage, +1V8 ¹	1.71	1.8	1.89	V
I/O operating range	-0.3		+1V8 + 0.3	V
Operating temperature	-40		85	°C

Table 4.2. Recommended operating conditions

¹ AFE, DAC, Analog comparator and USB is not usable in ATSAME70Q20A.

5.3 Electrical specification

The below table shows the XM112 electrical DC specification conditions, on XM112 connector J1, at T_A = 25°C:

Parameter	Min.	Typ.	Max.	Unit
Current into +1V8 supply pin			200	mA
I/O V _{IL} Low-level input voltage	-0.3		0.3 * +1V8	V
I/O V _{IH} High-level input voltage	0.7 * +1V8		+1V8 + 0.3	V
I/O V _{OL} Low-level output voltage			0.4	V
I/O V _{OH} High-level output voltage	+1V8 - 0.4			V
For drive and input current see ATSAME70Q20A data sheet, ref [2]				

Table 4.3. Electrical DC conditions



5.4 Power consumption summary

The below table summarizes the XM112 power consumption, maximum current ratings and average current ratings at +1V8 power terminal at $T_A = 25^\circ\text{C}$ and 1.8 V supply:

Parameter	Min.	Typ.	Max.	Unit
Average power consumption, 1 Hz sweep rate		3.1 ⁽¹⁾		mW
Average power consumption, 10 Hz sweep rate		9.6 ⁽¹⁾		mW
Average power consumption, 100 Hz sweep rate		81.3 ⁽¹⁾		mW
Idle current		0.89		mA

Table 4.4. Average power dissipation ratings at power terminal

¹ Measuring window set to 0.24 m, configuration with maximize on depth resolution used.

5.5 RF specification

The below table shows the XM112 RF specification:

Parameter	Min.	Typ.	Max.	Unit
Center frequency f_c		60.5		GHz
EIRP (Equivalent Isotropically Radiated Power)			10	dBm
HPBW (Half Power Beam Width), elevation plane		45		degrees
HPBW (Half Power Beam Width), horizontal plane		70		degrees

Table 4.5. XM112 RF specification



6 Reference design description

6.1 Schematics & BOM

The electrical schematics for the XM112 are found on the following pages:

REVISION RECORD			
LTR	ECO NO.	APPROVED:	DATE:

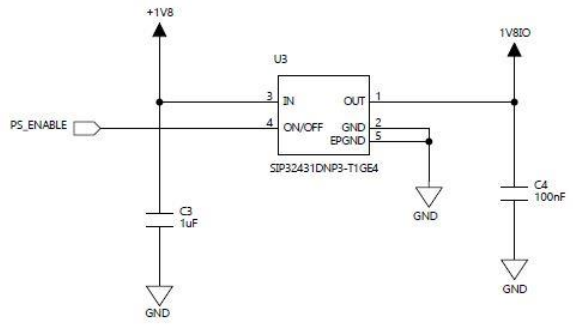
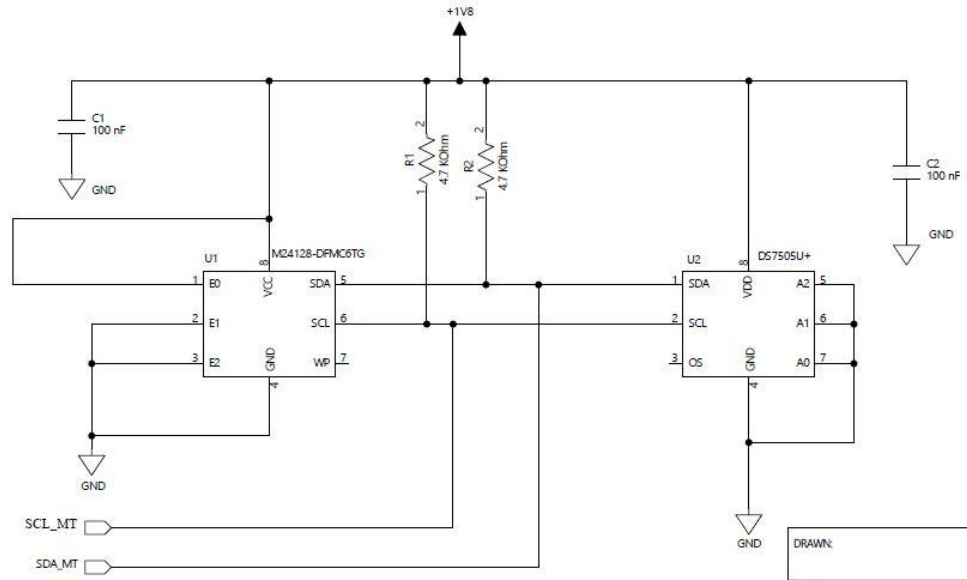
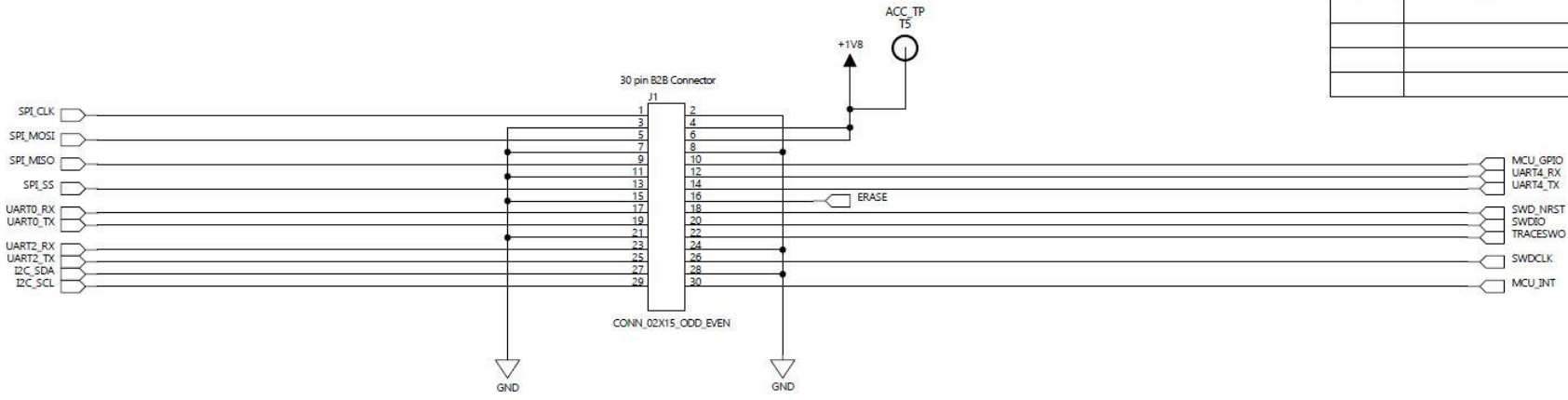

DRAWN:	DATED:
CHECKED:	DATED:
QUALITY CONTROL:	DATED:
RELEASED:	DATED:

COMPANY: Acconeer			
TITLE: XM112			
CODE:	SIZE: A3	DRAWING NO: November 26, 2018	REV: R1C
SCALE:			SHEET: 2 OF 4

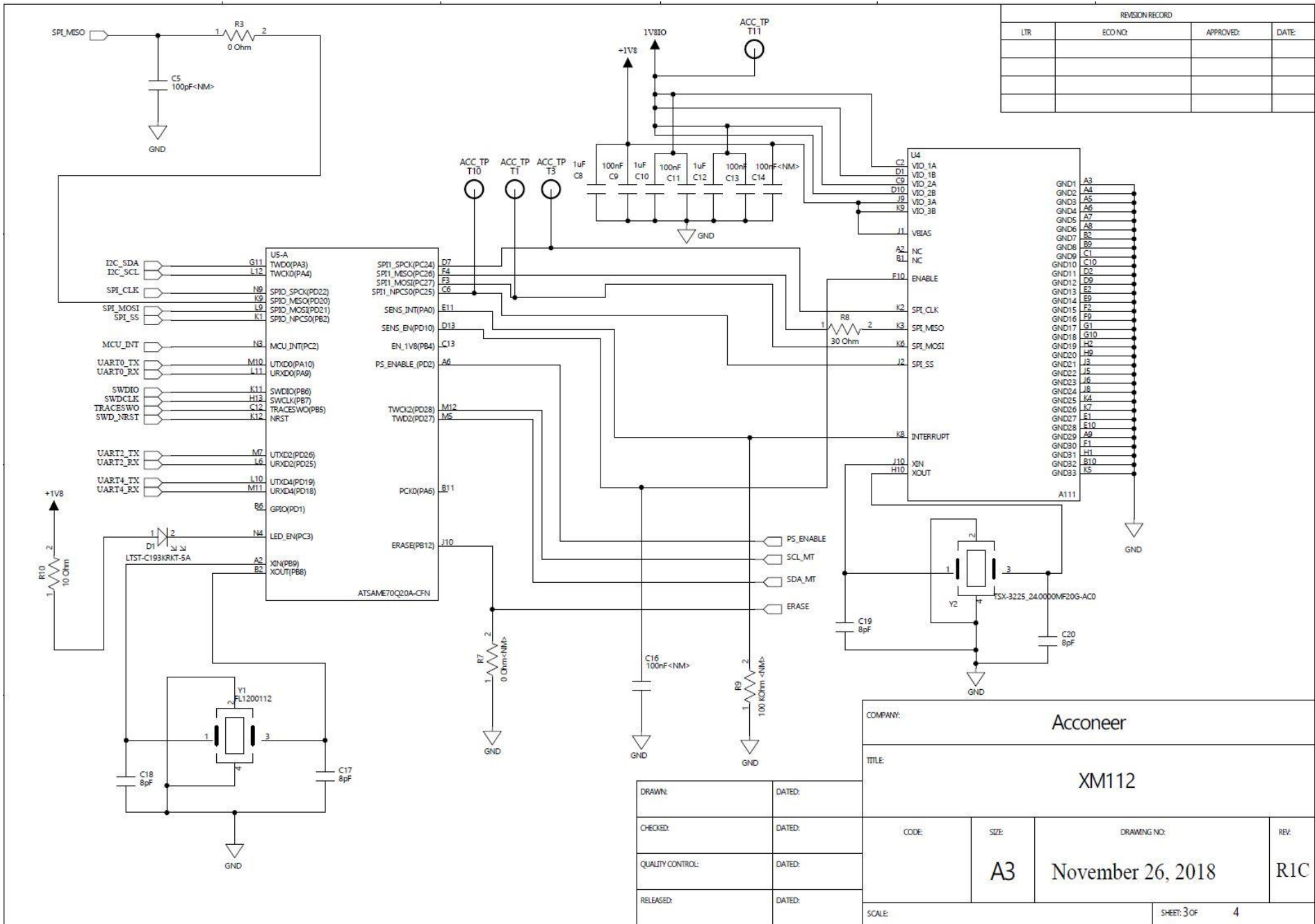

REVISION RECORD				
LTR	ECO NO.	APPROVED:	DATE:	

COMPANY:				Acconeer	
TITLE:					
XM112					
DRAWN:	DATED:	CODE:	SIZE:	DRAWING NO.:	REV:
CHECKED:	DATED:	A3		November 26, 2018	R1C
QUALITY CONTROL:	DATED:	SCALE:			
RELEASED:	DATED:	SHEET: 3 OF 4			

Bill of Material

Table 5.1 shows the BOM for XM112.

Component Ref.	Specification	QTY	Value	Comment
C3,C8,C10,C12,C31	1/UF/K/10V/X5R/1005	5	1 μ F	
C1,C2,C4,C9,C11,C13,C22,C23,C27,C28,C29,C30,C32,C33,C34,C35,C38	100/NF/K/50V/X7R/1005	17	100 nF	
C17,C18,C19,C20	8/PF/C/50V/NP0,C0G/1005	4	8 pF	
C21,C24	1608 10% 10V X5R 4.7uF	2	4.7 μ F	
R3	1005 J 0	1	0 Ohm	
R10	10/OHM/F/1005	1	10 Ohm	
R8	30/OHM/F/1005	1	30 Ohm	
R1,R2	1005 F 4.7K	2	4.7 kOhm	
U4	A111-002	1	N/A	PCR
U5	ATSAME70Q20A-CFN	1	N/A	MCU
U2	DS7505U+	1	N/A	Thermostat
U1	M24128-DFMC6TG	1	N/A	EEPROM 128k
U3	SIP32431DNP3-T1GE4	1	N/A	Leakage load switch
J1	DF40C-30DS-0.4V51/30-pin B2B connector receptacle	1	N/A	Manufacturer: Hirose
Y1	FL1200112/CRYSTAL_12 MHz	1	12 MHz	XTAL
Y2	TSX-3225 24.0000MF20G- AC0	1	24 MHz	XTAL
D1	LTST-C193KRKT-5A	1	N/A	LED RED
L3	BLM18PG471SN1	1	N/A	Ferrite Bead
L1	MLZ1608N100LT000	1	10 μ H	
C14,C16	<NM>	2	100nF<NM>	
C5	<NM>	1	100pF<NM>	
R7	<NM>	1	0 Ohm<NM>	
R9	<NM>	1	100 KOhm <NM>	

Table 5.1 XM112 BOM list



6.2 Component Placement Drawing

The component placement drawing of XM112 is found below:

Top side

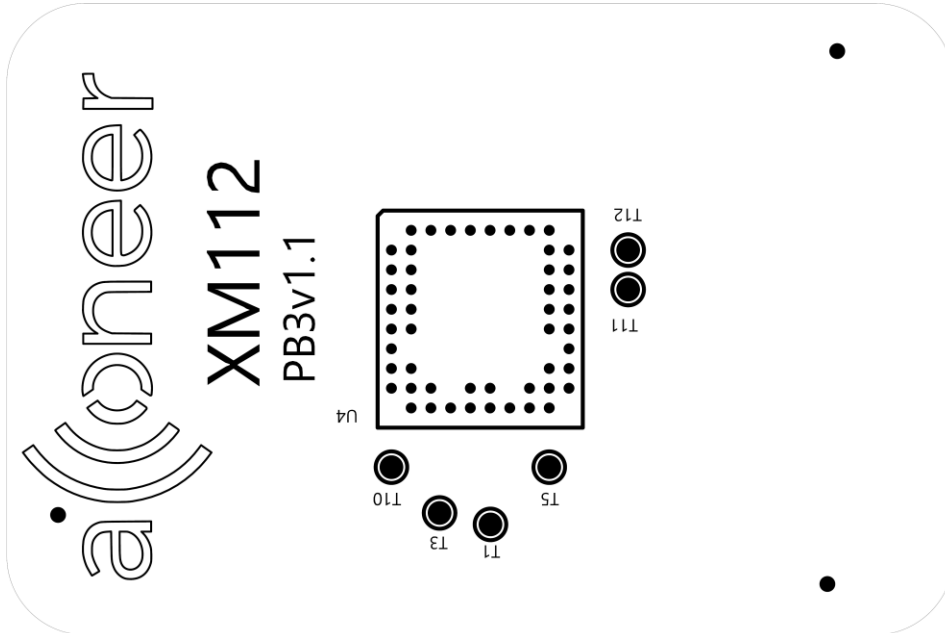

Bottom side:

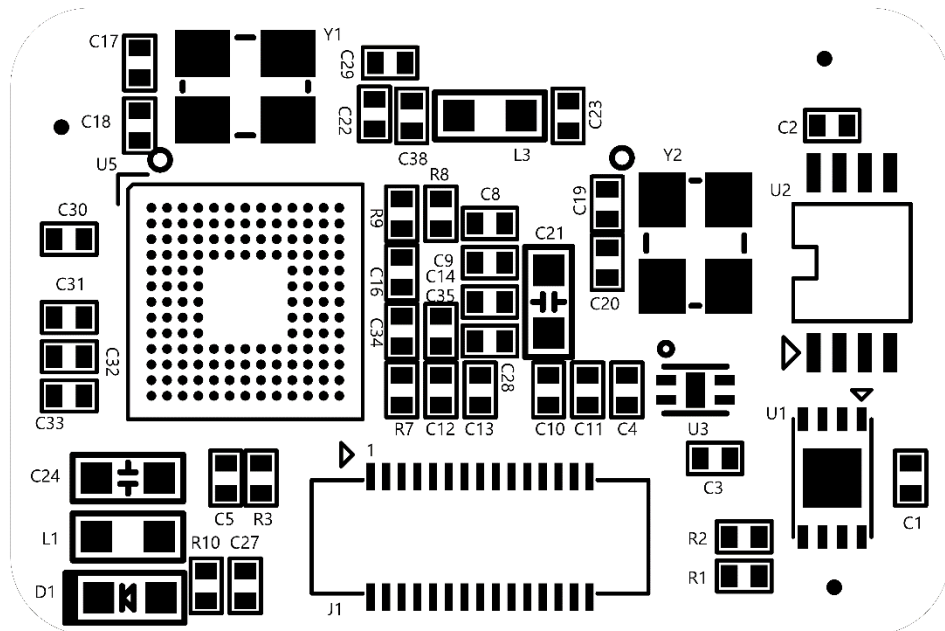



7 Mechanical specifications

XM112 Module outline – Top view

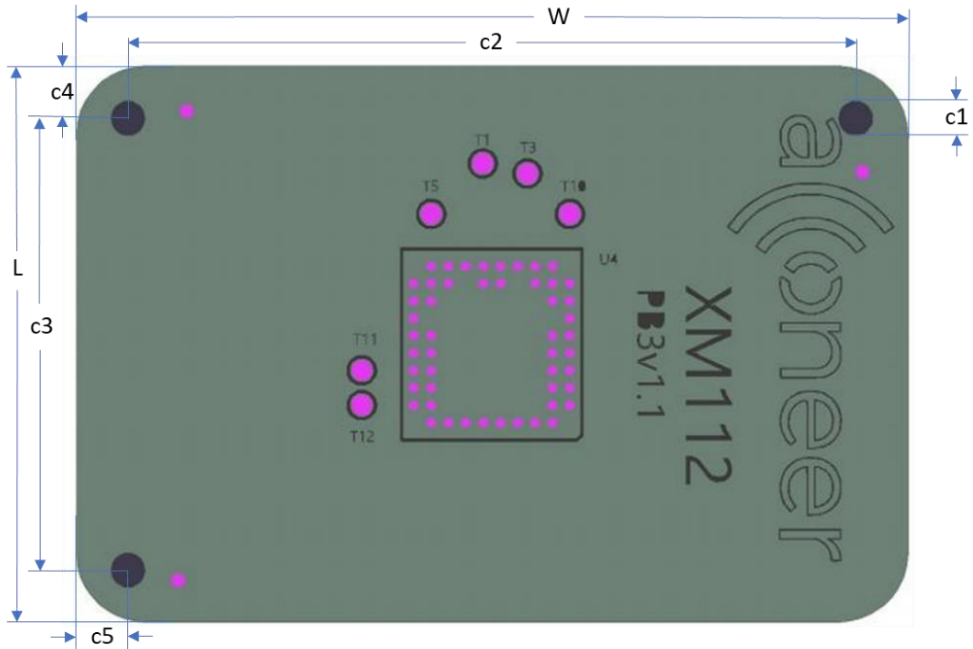

XM112 Module outline – Bottom view

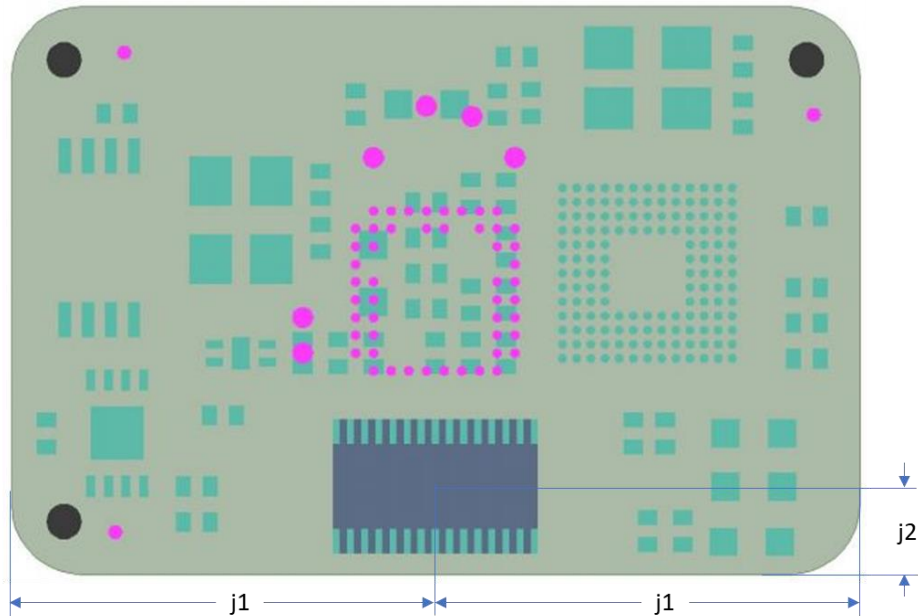



XM112 Module outline – Side view

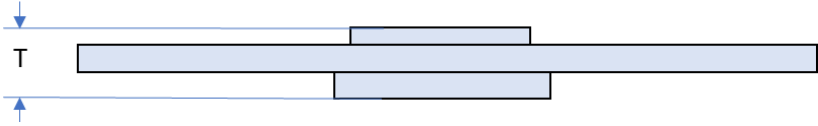

Distance	Value	Tolerance
W	24 mm	+/-0.127 mm
L	16 mm	+/-0.127 mm
T	3.3 mm	+/-0.1 mm
c1	1 mm	0.95 +/-0.076 mm
c2	21 mm	+/-0.127 mm
c3	13 mm	+/-0.127 mm
c4	1.5 mm	+/-0.127 mm
c5	1.5 mm	+/-0.127 mm
j1	12 mm	+/-0.177 mm
j2	2.5 mm	+/-0.177 mm



8 Reference documents

- [1] A111 Pulsed Coherent Radar (PCR) Datasheet:
<https://www.acconeer.com/products>
- [2] ATSAME70Q20A Datasheet:
<https://www.microchip.com/wwwproducts/en/ATSAME70Q20>
- [3] XM112 Module Evaluation Kit, User guide:
<https://www.acconeer.com/products>
- [4] XM112 Module Server, User guide:
<https://www.acconeer.com/products>
- [5] XB112 Radar Module Breakout Board, Product brief:
<https://www.acconeer.com/products>



Disclaimer

The information herein is believed to be correct as of the date issued. Acconeer AB (“**Acconeer**”) will not be responsible for damages of any nature resulting from the use or reliance upon the information contained herein. Acconeer makes no warranties, expressed or implied, of merchantability or fitness for a particular purpose or course of performance or usage of trade. Therefore, it is the user’s responsibility to thoroughly test the product in their particular application to determine its performance, efficacy and safety. Users should obtain the latest relevant information before placing orders.

Unless Acconeer has explicitly designated an individual Acconeer product as meeting the requirement of a particular industry standard, Acconeer is not responsible for any failure to meet such industry standard requirements.

Unless explicitly stated herein this document Acconeer has not performed any regulatory conformity test. It is the user’s responsibility to assure that necessary regulatory conditions are met and approvals have been obtained when using the product. Regardless of whether the product has passed any conformity test, this document does not constitute any regulatory approval of the user’s product or application using Acconeer’s product.

Nothing contained herein is to be considered as permission or a recommendation to infringe any patent or any other intellectual property right. No license, express or implied, to any intellectual property right is granted by Acconeer herein.

Acconeer reserves the right to at any time correct, change, amend, enhance, modify, and improve this document and/or Acconeer products without notice.

This document supersedes and replaces all information supplied prior to the publication hereof.

© 2018 by Acconeer – All rights reserved



Acconeer AB
IDEON Gateway
Scheelevägen 27
223 63 LUND
Sweden